

TAKSTAR® 得胜



无线麦克风 Wireless Microphone

用户手册
User Manual

目 录

Content

目 录	01
Content	01
前 言	02
Foreword	10
产品特性	02
Features	10
适用场合	02
Application	10
技术参数	02
Specification	10
标准配置	03
Product content	11
接收机功能	03
Receiver function	11
接收机LCD显示面板操作方法	04
Receiver LCD display and operation	12
麦克风使用和操作方法	05-06
Microphone operation	13-14
系统操作方法	07
System operation	15
注意事项	07
Note	15
安全警告	08
Caution	16
故障及解决方法	09
Trouble shooting	17

前言

尊敬的用户：

感谢您选购TAKSTAR无线麦克风，为了您能够更好的了解使用本产品，建议您在使用前仔细阅读本说明书。

若存在有疑问或者您有宝贵的建议，可通过拨打得胜官方服务热线
400 6828 333 或使用微信扫描二维码关注得胜官方公众号与我们联系。



产品特性

- 数字导频技术，有效解决相互串频现象；
- UHF 频段，锁相环（PLL）频率合成；
- 100×2 个信道，信道间隔 250KHz；
- 超外差二次变频设计，拥有较高的接收灵敏度；
- 静音电路有效降低麦克风开启和关闭的冲击噪声；
- 具备红外自动对频功能；
- 麦克风使用时间约为6-10 小时；
- 麦克风采用升压设计，电池电量下降时能保持整体性能；
- 麦克风离开人手静止后 3秒自动静音，5 分钟后自动节能进入待机状态，15 分钟后自动关机并且切断电源。

适用场合

- 适用于KTV、现场演出、大型会议等使用场合

技术参数

- 频率范围：645-693MHz
- 频率稳定度：±10ppm
- 可调信道数：100×2
- 频率响应：40Hz-18KHz
- 失真度：≤0.5% (at 1KHz)
- 信噪比：≥110dB
- 接收方式：超外差二次变频
- 调试方式：调频（FM）
- 发射功率：3-30mW
- 接收灵敏度：-95~-60dBm
- 接收范围：100 米（室内理想环境下）
- 发射器供电：2节 AA 电池
- 接收机供电：DC 12V
- 电源消耗：≤10W

标准配置

接收机	一台
手持式麦克风	两支
音频传输线	一条
电源适配器	一个
天线	两支
角码	一套
防滚圈	两个
尾套	两个
AA电池	四节
使用手册	一份

接收机功能和操作方法

前面板

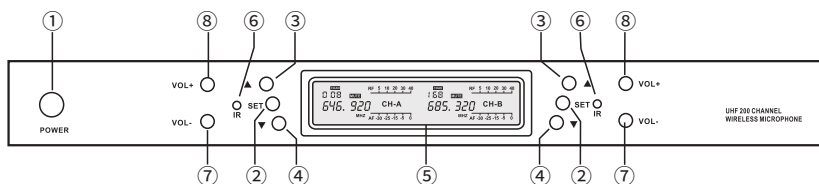

- ① 电源开关键：轻按电源开关，LCD屏亮，电源打开；再按电源开关键3秒钟，LCD屏熄灭，电源关闭。
- ④ 四个功能键：按②“SET”键可以选择左右，按③“▲”④“▼”键对当前选中的菜单状态进行改变，再按②“SET”键设置生效。
- ⑤ 液晶显示屏（LCD）：显示频道、静音状态、接收信号电平、音频电平等。
- ⑥ 红外对频窗口：配合“SET”键，将频道参数传至发射机。
- ⑦⑧ 音量调节按键。

后面板

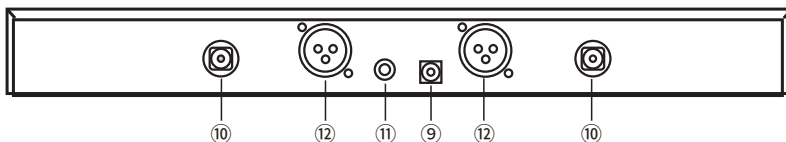

- ⑨ 电源开关插座：DC 12V/500mA电源输入插座，插座的中心电极连接正电压。
- ⑩ 天线插孔
- ⑪ 音频混合输出：将两个信号混合在一起输出。
- ⑫ 音频平衡输出：适合长距离连接使用，能有效降低由于连接线引起的杂讯。

接收机LCD显示面板操作方法

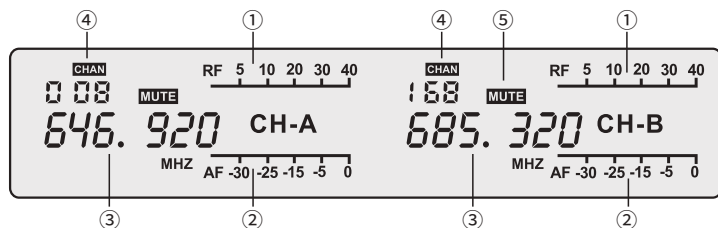

- ① 射频电平显示：显示接收到射频信号强度。
- ② 音频电平显示：显示音频信号的大小。
- ③ 频率菜单显示：显示当前的工作频率。
- ④ 信道菜单显示：CHAN亮时，显示当前的工作频率。
- ⑤ 静音显示：MUTE灯亮时，表示未收到射频信号。

1. 自动搜索空闲信道功能

在复杂环境下，人工去选择没有干扰的通道很费时，接收机配置了自动搜索无干扰信道功能，操作方式如下：

长按“SET”键2秒以上再松开，主机进入自动搜索无干扰信道功能，当主机搜索无干扰信道之后，会闪动显示当前搜索到无干扰信道，此时打开手持，把手持显示屏位置对准主机的“IR”发射窗口，再按一次“SET”键进行红外对频操作即可。

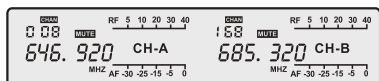

2. 主机加锁和解锁

关闭主机，按住主机左边“DOWN”键（频道减键）开机，主机即可实现加锁解锁；如果加锁，主机上的“钥匙”符号会显示；如果解锁，主机上“钥匙”符号就不显示。

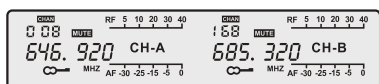

3. 内置隐藏调试模式

同时按住主机左右两边的“UP”键，进入ID加密菜单设置。此时主机显示“ID ON”按右边上下键切换。ID ON和ID OFF功能介绍，ID ON是正常模式下使用的设置，在这种模式下，主机只能和最后一次对频成功的手持使用，ID OFF是测试模式，在这种模式下，主机可以接收任何一支与其频点相同的手持。此项菜单建议不要去更改，以防串频。

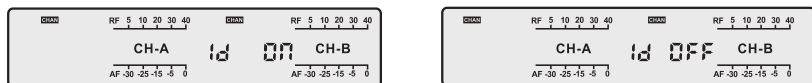

备注：由于每个频点都有各自的加密算法，因此，主机只能和最后一次对频成功的手持使用，如果出现手持和主机显示的频点一样，但是主机有信号没有声音，重新进行一次红外对频操作即可。

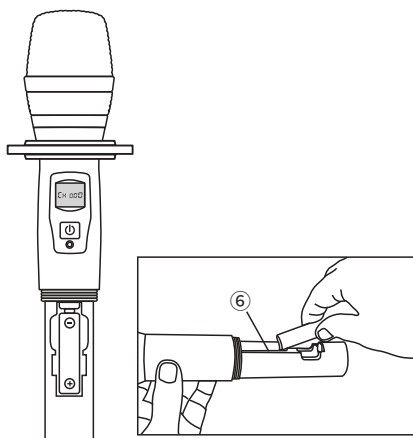
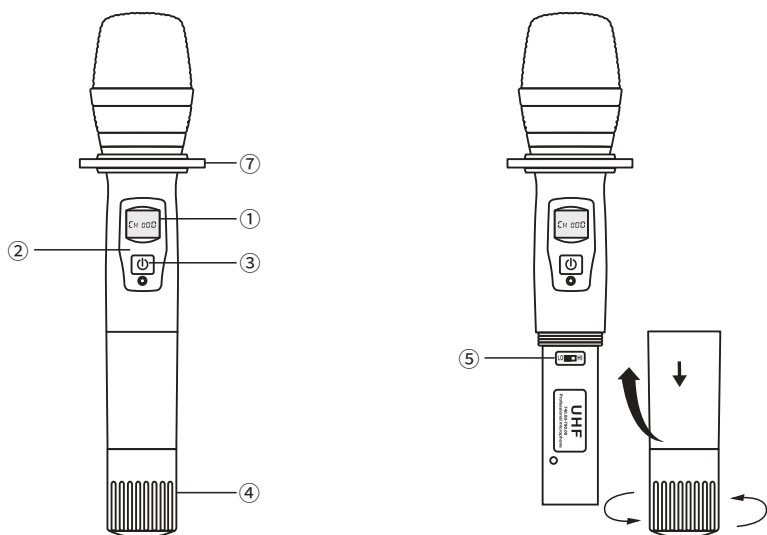

麦克风的外形结构说明

- ① 液晶显示屏
- ② 红外接收窗口
- ③ 电源开关
- ④ 尾筒
- ⑤ 高/低功率切换开关
- ⑥ 电池仓
- ⑦ 防滑圈

麦克风使用和操作方法

1. 感应功能打开与关闭

打开手持，在背光熄灭之后，按住电源按键不放（注意：要一直按着不放开），2秒后手持会正常关机（此时电源按键还是不放），等待10秒钟之后手持会自动开机，并显示SEN ON（表示感应功能打开）或者SEN OFF（表示感应功能关闭），此时松开电源按键，手持进入正常工作模式。打开和关闭感应功能都是一样的操作，只需重复一下操作即可。要注意的是，整个过程中手持的电源按键都是按着不松开的。

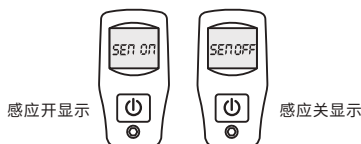

2. 高/低功率切换

为适应不同的使用场合，麦克风设计了高/低功率切换开关，当开关拨到高功率“H”位置时，麦克风的发射功率高，使用距离远（空旷有效使用距离约200米），功耗较大。当开关拨到低功率“L”位置时，麦克风的发射功率低，使用距离近（空旷有效使用距离约60米），功耗较小。用户可以根据实际情况自行选择设置。

3. 红外对频

按主机SET键即可进入红外对频模式。具体操作方式：把手持打开，手持的显示屏对准主机IR发射窗口，按一下主机SET键，手持会自动同步到主机设定的频点。

4. 开机和关机操作

向下轻按电源开关约2秒左右，麦克风显示屏亮起并且液晶屏幕会显示相关的工作信息（工作频率、信道、电池电量等信息）。在每次开机时要注意查看电池电量显示状态，根据实际情况要使用的时间长短来选择是否更换电池。一般情况下，一对普通的5号电池能够正常使用8小时。当电池电量为1格时，显示屏上会闪烁显示出低电压提示“LOW BAT”，说明电池电量即将消耗完，请更换电池。另外，显示屏的背光在麦克风开机后几秒钟就会自动熄灭进入节能模式，如果在使用时需要查看显示屏信息，轻按一下电源开关即可。按下电源开关不放约3秒左右，显示屏显示“OFF”，之后麦克风就会关机。当麦克风长时间不使用时，请把电池取出，以免电池漏液腐蚀电路板从而损坏麦克风。

5. 安装麦克风电池

从包装中取出手持麦克风，旋开尾筒，按照标示的极性装入2节5号电池，然后旋回尾筒。

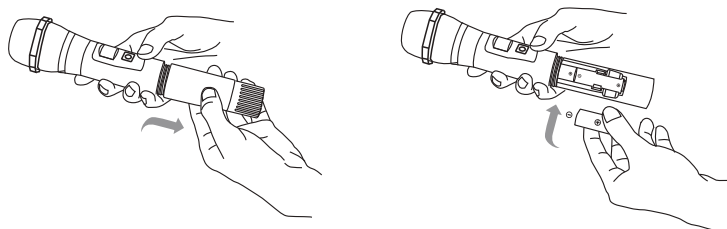

系统操作方法

1. 连接好整套音响系统;
2. 将接收机及功放（卡拉OK功放机）的音量调小;
3. 按前级到后级顺序打开整套音响系统的电源;
4. 打开发射机的电源;
5. 调整套音响系统的音响效果：先把接收机音量电位器调节到 midpoint 位置，开启麦克风开关，对着麦克风讲话，使音量合适，再仔细调整音量控制器，使声音清晰，音量适当。必需时拿着话筒在整个使用场地进行“走场”，过程中话筒不产生啸叫为合适;
6. 如无线接收机系统有问题，请参照说明书故障排除解决问题，不在故障排除问题内时请专业人士解决或直接联系经销商;
7. 使用完后，先关闭发射机电源，再按先后级到前级的顺序关闭整套音响系统的电源。

注意事项

1. 天线的架设位置直接影响接收机的接收效果，所以要特别注意正确的安装方法，重要的原则是保持麦克风和接收机之间的距离越短越好;
2. 避免把接收机放在计算机或其它产生RF（射频）信号的设备旁边;
3. 避免把接收机放在设备架的底层，除非在远距离安装天线;
4. 本接收机系统可满足200支无线麦克风同时使用，且互不干扰，但需要专业人士专门调试好不同频道。

安全警告

为避免电击、过高温度、着火、辐射、爆炸、机械危险以及使用不当等可能造成的人身伤害或财产损失，使用本产品前，请仔细阅读并遵守以下事项：

1. 使用产品时请确认所连接设备与本产品功率是否匹配以及合理调整音量大小，不要在超过产品功率及大音量下长时间使用，以免造成产品异常和耳朵听力损伤；
2. 使用中若发现有异常（如冒烟、异味等），请立即关闭电源开关并拔掉电源插头，然后将产品送经销商检修；
3. 若产品需要使用可拆装电池时，严禁使用外壳绝缘材料破损的电池；请不要为非充电电池充电；
4. 废弃电池需放入指定的分类垃圾桶，不可作为儿童玩具或直接丢弃，以免造成安全隐患或影响环境；
5. 本产品及配件都应放置在室内干燥通风处，勿长期存放在潮湿、灰尘多的环境，使用中避免靠近裸露火源、碰到液体物质、雨淋、产品进水、过度碰撞、抛掷、振动本机及覆盖通风孔，以免损坏其功能；
6. 若产品需要固定于墙壁或天花板上时，请确保固定到位，防止因固定强度不足导致产品发生跌落危险；
7. 使用该产品时需遵守相关安全规定，法律法规明确禁止使用场合请勿使用本机，以免导致意外事故；
8. 请不要自行拆机改装或维修，以防止出现人身伤害，如有问题或服务需求请联系当地经销商跟进处理；
9. 只能使用本机附送或同规格的电源适配器。若产品无附送电源适配器时，可在5000米以下高度及热带和寒冷气候条件下正常使用；若产品有附送电源适配器时，适用海拔及气候条件由适配器决定，使用前请阅读并理解适配器上的图标含义。示例如下：



仅适用于海拔2000
米以下地区使用



仅适用于非热带
气候条件下使用

故障及解决方法

下表列出一些常见的故障及解决方法，如果您无法解除故障，请与经销商联系。

出现问题	解决方法
没有声音；（状态：接收机RF显示器不亮）	<ul style="list-style-type: none">● 检查发射机和接收机的电源开关，是否处于“ON”（接通）的位置。● 检查电池正负极性是否调乱。● 检查接收机的天线连接情况。● 确保天线与发射机之间无障碍物遮挡。
没有声音；（状态：接收机RF显示正常，AF显示正常）	<ul style="list-style-type: none">● 检查接收机的音量旋钮是否有调小。● 检查接收机与功放之间的连接是否正确。
没有声音；（状态：接收机RF显示正常，AF显示不正常）	<ul style="list-style-type: none">● 检查接收机的电源是否打开。● 必要时对换发射机的拾音话筒。
接通发射机，收到信号有杂音或有外音干扰	<ul style="list-style-type: none">● 检查电池是否安装牢固。● 排除附近的射频干扰源。● 如果使用吉他或其它乐器，检查连接情况。● 两个发射机可能使用相同的频率，查找并关闭其中一个。● 信号可能太弱，重新调整天线的位置，尽可能向发射机靠近。● 更换其它频道。
发射机关闭后，接收机有噪音	<ul style="list-style-type: none">● 调节接收机的接收灵敏度调节钮“SQ”旋钮。● 排除射频噪音源。● 重新调整接收机或天线位置。
发射机演出场地移动，过程中声音偶然有丢失	<ul style="list-style-type: none">● 调节接收机的接收灵敏度调节钮“SQ”旋钮。● 重新放置接收机，并进行“走场”试验观察RF显示器。● 如果发现声音丢失，将该点标出，演出时避免走到此处。
无法打开发射机	<ul style="list-style-type: none">● 更换发射机电池。

Foreword

Dear Customer,

Thank you for purchasing Takstar G5 wireless microphone. Please read the user manual carefully before operation and keep it for reference in future. If you have any question or suggestion, please contact our local dealer.

Features

- Digital wave guide technology effectively solves the crosstalk problem
- UHF frequency, PLL design
- 100×2 channels, 250KHz interval;
- Double superheterodyne design, high receiving sensitivity
- The mute circuit effectively reduces ON/OFF noise
- Infrared matching function
- Microphone operation time approximate 6-10h
- Voltage boosting design keeps the microphone performance during low voltage
- The microphone automatically mutes after being unheld by hand for 3 seconds, and stands by for 5 minutes, and powers off for 15 minutes

Application

- KTV, live performance, large conference

Specification

- Frequency Range: 645-693MHz
- Frequency Stability: ± 10 ppm
- Channel Quantity: 100×2
- Frequency Response: 40Hz-18KHz
- Distortion: $\leq 0.5\%$ (at 1KHz)
- S/N Ratio: ≥ 110 dB
- Receiving: double superheterodyne
- Modulation: FM
- Transmission Power: 3-30mW
- Receiving Sensitivity: -95~-60dBm
- Receiving Range: 100m (ideal environment in room)
- Transmitter Power Supply: two AA batteries
- Receiver Power Supply: DC 12V
- Power Supply Consumption: ≤ 10 W

Product Content

Receiver	1pc
Handheld microphone	2pcs
Audio cable	1pc
Power adapter	1pc
Antenna	2pcs
Corner	1set
Anti-skidding loop	2pcs
Tail tube	2pcs
AA battery	4pcs
User manual	1pc

Receiver function and operation

Front panel

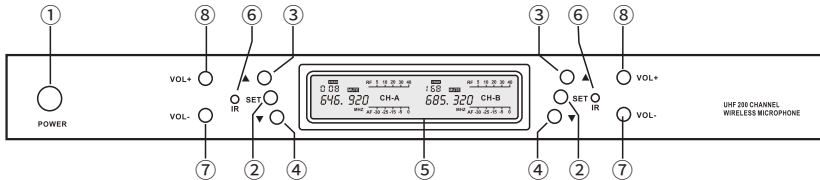

- ① Power switch: press the power switch to turn on the receiver, and LCD screen lights up.
Press the power switch again for 3 seconds to turn off the receiver, and LCD screen lights off.
- ④ Four function buttons: press ② “SET” to select left or right. Press ③ “▲” ④ “▼” to change the selected item, and then press ② “SET” to confirm.
- ⑤ LCD: it displays channel, mute, receiving signal level, audio level, etc.
- ⑥ Infrared matching window: used with “SET” button to send the channel parameter to the transmitter.
- ⑦⑧ Volume buttons.

Rear panel

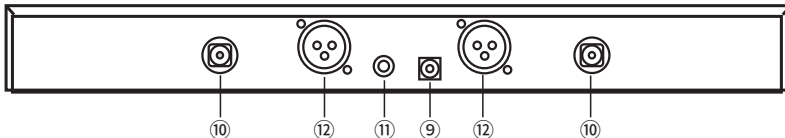

- ⑨ Power connector: DC 12V/500mA power input connector. The central pin connects with + voltage.
- ⑩ Antenna connector
- ⑪ Audio combo output: audio combo output connector.
- ⑫ Audio balanced output: suitable for long distance connection.

Receiver LCD display and operation

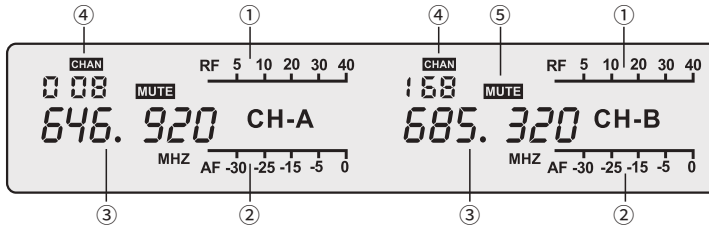

- ① RF level display: it displays the receiving signal level.
- ② Audio level display: it displays the audio level.
- ③ Frequency display: it displays the current working frequency.
- ④ Channel display: when CHAN lights up, it displays the current working frequency.
- ⑤ Mute display: when MUTE lights up, this means the RF signal is not received.

1. Automatically search channel

The receiver automatically searches channel to avoid manually search. The operation is as below:

Keep pressing SET button for 2 seconds and then release. The receiver searches channel automatically. When it searches the channel without interference, it flashes. Turn on the handheld microphone, and point the microphone to the receiver IR window. Press SET button again for infrared matching.

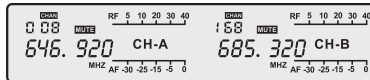

2. Lock and unlock the receiver

Turn off the receiver. Press the DOWN button and meanwhile turn on the receiver to lock or unlock the receiver. During locking, the KEY symbol appears. During unlocking, the KEY symbol disappears.

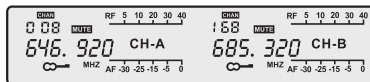

3. Hide the setting mode

Press UP buttons on the left and right simultaneously. Turn on the receiver to enter into ID encode menu setting. The receiver displays ID ON. Press UP and DOWN buttons to switch. ID ON and ID OFF function introduction: ID ON is the setting mode in normal status. In this mode, the receiver only works with the last matching handheld microphone. ID OFF is the test mode. In this mode, the receiver works with the microphone which has the same frequency with that of the receiver. Do not change items in this mode please to avoid crosstalk.

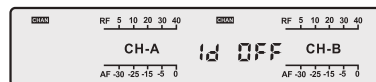
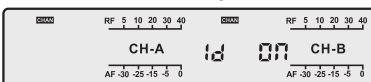

Note: each frequency has its encoded algorithm, so the receiver only works with the last matched handheld microphone. If the handheld microphone and receiver have the same frequency, but the receiver has signal and no sound, use the infrared matching to match once again.

Microphone operation

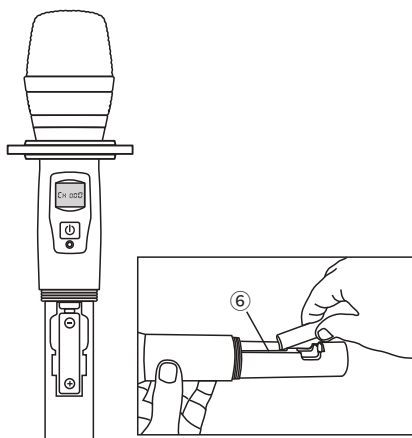
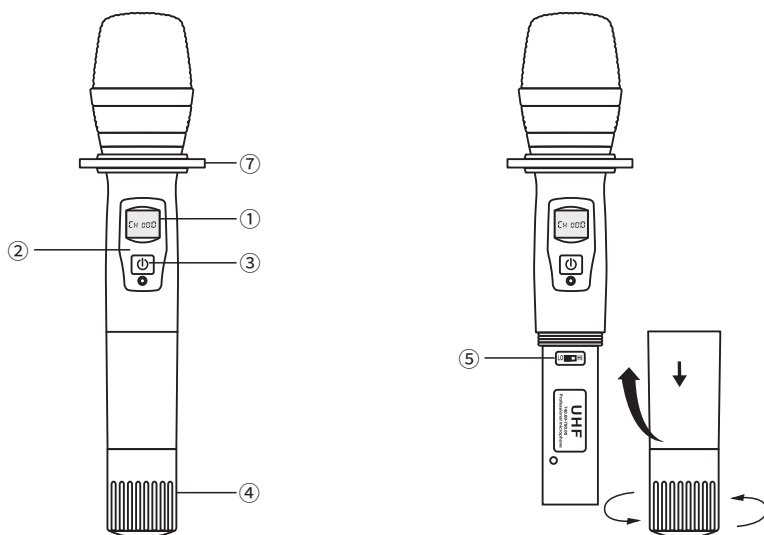

Microphone structure instruction

- ① LCD
- ② IR window
- ③ Power switch
- ④ Tail tube
- ⑤ High/low power switch
- ⑥ Battery compartment
- ⑦ Anti-skidding loop

Microphone operation

1. Sensor function ON/OFF

Turn on the handheld microphone. After the backlight lights off. Keep pressing the power switch (note: keep pressing). After two seconds the microphone turns off and then turns on after 10 seconds, and it displays SEN ON (This means the sensor function is on) or SEN OFF (this means the sensor function is off). Release the power switch, and then the microphone enters into normal operation mode. The sensor function ON/OFF have the same operation. Just repeat once again. Please note, keep pressing the power switch during the whole process.

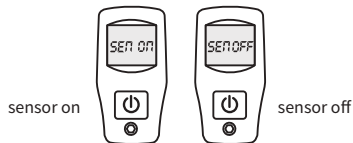

2. High/low power switching

The microphone is designed with high/low power switch for different application. Set the switch to H position for high power transmission and long operation range (open area 200m), but the power consumption is high. Set the switch to L position for low power transmission and near operation range (open area 60m), but the power consumption is low. User can select the operation according to actual situation.

3. Infrared matching

Press the receiver SET button to enter into infrared matching mode. Operation: turn on the handheld microphone, and point the handheld microphone to the receiver IR window, and then press SET button. The microphone will match the frequency with that of the receiver.

4. ON/OFF operation

Press the power switch for two seconds. The microphone LCD lights up and displays the operation information(working frequency, channel, battery power, etc). Please check the battery power when you turn on the microphone every time. Generally, one pair of AA batteries lasts for 8h operation. When the battery power is low, it displays LOW BAT. This means the battery power is low, and replace the batteries in time. Furthermore, the LCD backlight lights off after the microphone is turned on for several seconds. If you want to check the LCD information, press the power switch. Keep pressing the power switch for 3 seconds, and LCD displays OFF, then the microphone is turned off. If the microphone will not be used for a long time, please take out the batteries to avoid microphone damage.

5. Assemble the batteries

Disassemble the tail tube. Put two AA batteries into the battery compartment. Assemble the tail tube.

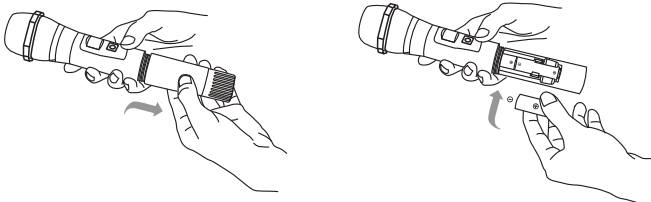

System operation

1. Connect the whole audio system well.
2. Set the volume of receiver and power amplifier (Karaoke power amplifier) to minimum.
3. Turn on the unit power switch of the audio system in the order from the front unit to the rear unit.
4. Turn on the transmitter power switch.
5. Adjust the audio effect of the audio system: set the receiver volume knob to middle position. Turn on the microphone power switch. Speak to the microphone and adjust to proper volume. Walk during speaking to the microphone. Please pay attention to avoid the microphone feedback.
6. If the receiver has problem, refer to the TROUBLE SHOOTING section. If the problem still can not be solved, please contact the local dealer.
7. After the operation, turn off the transmitter first. Turn off the power switch of the audio system in the order from the rear unit to the front unit.

Note

1. The antenna position affects the receiving effect of the receiver, so please pay attention to the assembly method. The important principle is keeping microphone close to the receiver.
2. Do not put the receiver near to computer or the equipment which generates RF signal.
3. Do not put the receiver to the bottom layer in the rack only if you assemble external antenna.
4. The receiver system can be used with 200 microphones simultaneously without interference. Please ask qualified technician for system setting.

Caution

To avoid personal injury or property loss caused by electric shock, over temperature, fire, radiation, explosion, mechanical risk and improper use, please read carefully and abide by the following items before operation:

1. Please check if the power of the connected equipment matches with that of this product before operation. Adjust the volume to proper level during operation. Do not operate at over-power or high volume level for a long time to avoid abnormal functioning or hearing loss.
2. If abnormal phenomenon (smoke, abnormal smell) happens, please turn off the power switch and disconnect the power plug with power socket, and send the product to local dealer for maintenance.
3. Using battery with broken insulation material is forbidden. Please do not charge the non-rechargeable battery.
4. Put the waste battery into classified dustbin rather than used as toy by children or discarded directly to avoid potential danger or affecting the environment.
5. The product and accessories should be put in dry and ventilated place rather than humid or dusty environment. Prevent the product from fire, liquid, rain, water, over-colliding, throwing, vibrating, vent hole covered to avoid function damage.
6. When the product needs to be installed on wall or ceiling, please fix it tightly to avoid dropping risk.
7. Please abide by safety rules during operation. Do not use the product in the place prohibited by regulation or law to avoid accident.
8. Do not disassemble or repair the product by yourself to avoid personal injury. If you have question or need service, please contact the local dealer.
9. Only use the supplied power adaptor or equivalent. If the product is supplied without power adaptor, it can be used normally under the altitude below 5000m and tropical or cold climate condition; if the product is supplied with power adaptor, the applicable altitude and climate condition of the product is subject to the power adaptor, below are the examples of the meaning of the power adaptor icons:



Applicable to the altitude below 2000m only



Applicable to the non-tropical climate condition only

Trouble shooting

Problem and trouble shooting are listed as below. If the problem is still can not be solved, please contact local dealer.

Problem	Trouble shooting
No sound (status: the receiver RF does not light up).	<ul style="list-style-type: none"> ● Check if the transmitter and receiver power switches are set to ON. ● Check if the battery polar is reversed. ● Check the receiver antenna connection. ● Make sure there is no obstacle between the antenna and the transmitter.
No sound (status: the receiver RF displays normally, AF displays normally).	<ul style="list-style-type: none"> ● Check if the receiver volume is set to minimum. ● Check if the receiver is connected with power amplifier correctly.
No sound (status: status: the receiver RF displays normally, AF does not display normally).	<ul style="list-style-type: none"> ● Check if the receiver is turned on. ● Change the transmitter cartridge and check the result.
Match with the transmitter. The received signal has noise or external interference.	<ul style="list-style-type: none"> ● Check if the battery is assembled well. ● Eliminate the RF interference source nearby. ● If you use guitar or other instrument, check the connection. ● Check if two transmitters are using the same frequency. Check and cancel one. ● The signal is too weak. Adjust the antenna position again. Put the antenna close to the transmitter. ● Change to other channel
Turn off the transmitter, but the receiver has noise.	<ul style="list-style-type: none"> ● Adjust SQ knob to change the receiver sensitivity. ● Eliminate the RF noise source. ● Adjust the position of receiver or antenna.
Move the transmitter in the application venue. It has intermittent signal.	<ul style="list-style-type: none"> ● Adjust SQ knob to change the receiver sensitivity. ● Change the receiver position and check RF display. ● If there is intermittent signal, do not walk to the this position during performance.
The transmitter can not be turned on.	<ul style="list-style-type: none"> ● Change the transmitter battery.



注意事项:

1. 本单为保修凭证, 请用户妥善保管, 如有遗失, 恕不保修或退换。
2. 保修期限制: 购买之日起十二个月内。
3. 除了不可抗力事件损坏外, 由本公司负责, 免费维修。
4. 如属保管不善或使用不当造成的损坏, 维修点将酌情收费。
5. 擅自拆卸维修者, 不予保修。
6. 以上保修条款仅限于中国市场适用 (不包含港澳台地区)。

产品服务保证书

姓名: _____ 电话: _____ 地址: _____

商品: _____ 型号: _____ 购买日期: _____ 年 ____ 月 ____ 日

维修记录栏(由维修员填写)	维修员签名	日期

◆ 广东得胜电子有限公司 ◆ 电话: 400-6828-333 ◆ 地址: 广东省惠州市博罗县龙溪镇富康一路2号



扫一扫，了解更多产品
Scan for more
product information

广东省电声工程技术研究开发中心 广东得胜电子有限公司制造

地址：广东省惠州市博罗县龙溪街道富康一路2号

服务热线：400 6828 333 传真：0752 6383950

邮箱：xs@takstar.com

网址：www.takstar.com

Guangdong Takstar Electronic Co., Ltd.

Address: No. 2 Fu Kang Yi Rd., Longxi Boluo

Huizhou, Guangdong 516121 China

Tel: 86 752 6383644 Fax: 86 752 6383952

Email: sales@takstar.com

Website: www.takstar.com